

Drawer Construction Detail

For the past 23 years, Southwest Contract has integrated a unique drawer construction to provide a lifetime of use within our items. We combine 16-gauge steel sides with 5/8" thick laminated backs and bottoms to provide ultimate strength in drawer construction.

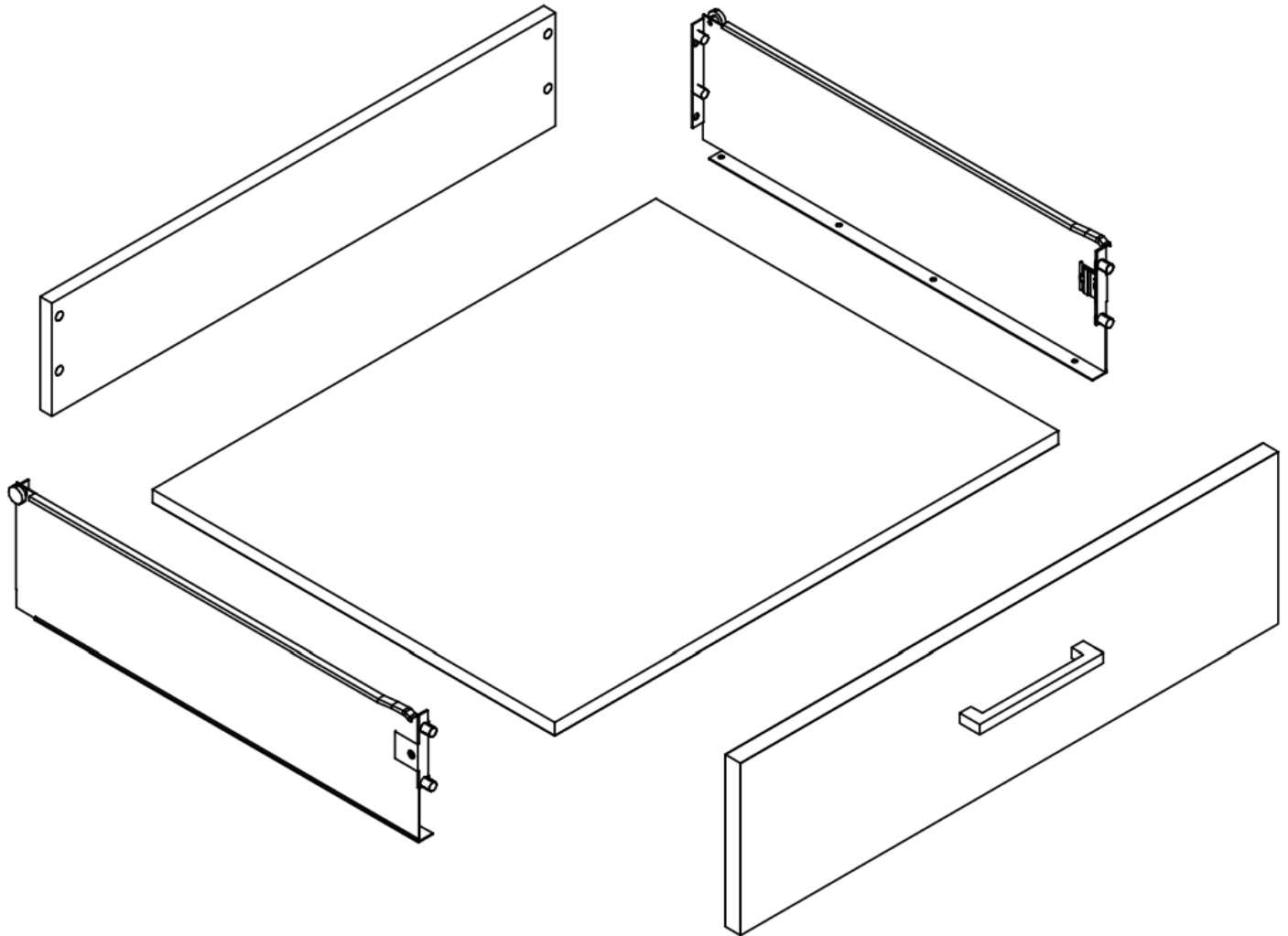

Note that the laminated bottom panel is supported by the steel flange on each of the steel drawer side panels and is screwed in place.

The laminate back panel and drawer front attaches to each drawer side using nylon expansion inserts and screws. In addition to the strength and durability of this type of construction, the drawer can be cleaned and sanitized with spray cleaning solutions and sanitizers. The standard white laminate drawer provides a clean look while providing resistance to stains and smells, eliminating the need for contact paper.

